

Faculty of Science		كلية العلوم
Department of Mathematics		قسم الرياضيات
امتحان نهائي الفصل الدراسي الثاني 2024 - 2025		
التاريخ: 2024-5-28		
الزمن: ساعتان	الدرجة: الرابعة علوم	المادة: هيدروديناميكا ومرونة
	الشعبة: رياضيات	الدرجة الكلية: 50 درجة
	رقم المقرر ورعده: 431 ر	

اجب عن اربعة أسئلة فقط مما يلي: (درجة كل سؤال 12.5)

السؤال الأول:

1- (ا) كيف يمكنك تحديد الاجهادات والاتجاهات الأساسية (6.5 درجة)

(ب) في جسم من مجهد وجد أن مركبات الاجهاد تعطي الصورة (6 درجات)

$$\delta_x = 10, \delta_y = 20, \delta_z = 10, \tau_{xy} = 6, \tau_{xz} = 8, \tau_{yz} = 4$$

أوجد مركبات الاجهاد بالنسبة لمجموع الاحداثيات (u, v, w) الناتجة بدوران مجموع الاحداثيات (x, y, z)

قدره 45° حول المحور ox

السؤال الثاني:

2- (ا) اثبت أن مجسم الانفعالات معادلة من الدرجة الثانية (6 درجات)

(ب) أوجد مركبات متجه الازاحة \bar{u} اذا علم أن مركبات الانفعال هي: (6.5 درجة)

$$\varepsilon_x = ay, \varepsilon_y = by, \varepsilon_z = by, \varepsilon_{xy} = \varepsilon_{xz} = \varepsilon_{yz} = 0$$

السؤال الثالث:

3- (ا) استنتج المعادلة الاتجاهية المرنة في الصورة الديناميكية (6.5 درجة)

(ب) سائل غير لزج يحيط فقاعة R_0 نصف قطرها الابتدائي وضغطها الابتدائي p_0 . أثر ضغط P عند ماله نهاية

في السائل ونتيجة لذلك بدأت الفقاعة في الانكماش من مرحلة السكون ($\gamma = 0$) أوجد السرعة $\frac{dR}{dt}$ النصف قطرية لحدود الفقاعة

علما بأن كثافة السائل ثابتة ومعادلة الحالة للفقاعة $const = \frac{p}{\rho^2}$ (6 درجات)

السؤال الرابع: (12.5 درجة)

4- اشتق معادلة نافير-ستوكس لمائع لزج غير قابل للانضغاط ومن ثم ناقش كتطبيق عليها سريان كوتى-

السؤال الخامس: (12.5 درجة)

5- ناقش مسألة رايلي-تايلور للاستقرار وأوجد معادلة التشتت وبين متى يكون النظام مستقر أو غير مستقر

اعداد: ا د محمود حامد محمد الله و د حسين السيد حماد مع التميز والنجاح

Question Five: (10 marks = 3+3+4)

1. Find the Laurent series of $f(z) = \frac{1}{z^2 - 3z + 2}$; $D: 0 < |z-1| < 1$, and $\oint_D f(z) dz$.
2. Calculate the value $\max_{|z|=1} |z^2 + 1|$
3. Let $f(z)$ be analytic function inside and on the boundary C of a simply-connected region R . Prove that Cauchy's integral formula $f(a) = \frac{1}{2\pi i} \oint_C \frac{f(z)}{z-a} dz$, and evaluate the integral $\oint_C \frac{e^{2z}}{z^2-1} dz$; $C: \left|z - \frac{1}{2}\right| + \left|z + \frac{3}{2}\right| = \frac{5}{2}$.

Question Six: (10 marks = 5+5)(Answer only Two)

1. By using contour integration, evaluate the integral $\int_0^{2\pi} \frac{1}{5 + 3\cos(\theta)} d\theta$.
2. If $f(z)$ is analytic function with derivative $f'(z)$ which is continuous at all points inside and on a simple closed curve C , Prove that $\oint_C f(z) dz = 0$, and evaluate the integral $\oint_{|z|=1} e^z dz$.
3. Evaluate the following integrals
(a) $\oint_C z dz$; $C: x=2y$, from $(0,0)$ to $(2,1)$ (b) $\oint_C z dz$; $C: x^2=4y$, from $(0,0)$ to $(2,1)$.
(c) $\oint_C z dz$; C : the lines from $(0,0)$ to $(2,0)$, and from $(2,0)$ to $(2,1)$.

With best wishes,,, Dr. Ayman Shehata

Arab Republic of Egypt
Ministry of Higher Education
Assiut University
Faculty of Sciences
Department of Mathematics



Final Term Exam (2nd Term)
Second Semester of the year 2024/2025
Date: 21/5/2025
Time : 3 hours

Course: Complex Analysis

Code: Math. 412

Testing degree: 50 marks

Answer only five of the following questions:

Question One: (10 marks = 4+3+3)

1. If $z_1 = 1 + i, z_2 = 1 - i$, find $z_1 - z_2, \frac{z_1}{z_2}, \operatorname{Re}(2z_1 + 3z_2), \operatorname{Im}(z_1^{-1})$.
2. Compute the limit $\lim_{z \rightarrow -i} (|z|^2 - i\bar{z})$.
3. Prove that $u(x, y) = e^{-x}(x \sin(y) - y \cos(y))$ is **harmonic**, and find $f(z)$.

Question Two: (10 marks = 5+5) (Answer only Two)

1. Prove that $|z_1 + z_2|^2 + |z_1 - z_2|^2 = 2(|z_1|^2 + |z_2|^2)$
2. Find the residues (a) $f(z) = \tan(z)$ (b) $f(z) = \frac{z^2}{(e^z + 1)^2(z - 2)}$
3. Calculate the value of the expressions (a) $(-i)^i$ (b) $\log(1 - i\sqrt{3})$ (c) $e^{\frac{\pi}{2}i}$

Question Three: (10 marks = 5+5) (Answer only Two)

1. By using contour integration, evaluate the integral $\int_{-\infty}^{\infty} \frac{1}{x^4 + 1} dx$.
2. Prove that the function $f(z) = \sin(z)$ is **uniformly continuous** in complex plane
3. Find the principal argument $\operatorname{Arg}\left(\frac{1}{-2 - 2i}\right), \operatorname{Arg}\left((\sqrt{3} - i)^6\right)$

Question Four: (10 marks = 3+3+4)

1. Using Cauchy's residue theorem, evaluate the integral $\int_{|z|=2} \frac{e^{3z}}{z^2(z-1)} dz$.
2. Find the Mobius transformation which maps the points $z = 0, -i, -1$ into $w = i, 1, 0$.
3. Evaluate the following integrals

$$(a) \oint_{|z|=1} \frac{1}{z-i} dz \quad (b) \int_0^{2\pi} \sin^2\left(\frac{\pi}{3} + 2e^{i\theta}\right) d\theta \quad (c) \oint_{|z-i|=\frac{1}{2}} \frac{2z-1}{z^2-z} dz$$

Question 4: Answer the following question (10 points)

Build FP-Tree **Only** from the following database:

TID	Items
1	{a,b}
2	{b,c,d}
3	{a,c,d,e}
4	{a,d,e}
5	{a,b,c}
6	{a,b,c,d}
7	{a}
8	{a,b,c}
9	{a,b,d}
10	{b,c,e}

Question 5: Answer the following question (10 points)

The following dataset will be used to learn a decision tree for predicting whether a mushroom is edible or not based on its shape, color and odor.

Shape	Color	Odor	Edible
C	B	1	Yes
D	B	1	Yes
D	W	1	Yes
D	W	2	Yes
C	B	2	Yes
D	B	2	No
D	G	2	No
C	U	2	No
C	B	3	No
C	W	3	No
D	W	3	No

Draw the full decision tree that would be learned for this data

End Questions

Best Wishes

Dr. Amal Abdelazim

Answer the following questions

Question 1: Complete the following spaces (10 points) (0.5 point fore each space)

- 1) is the process of discovering interesting patterns (or knowledge) from large amounts of data, that patterns must be,,
- 2) is a step in KDD process where multiple data sources may be combined.
- 3) Data Mining Tasks divided into two main tasks,
- 4),, are three examples of data mining tasks.
- 5),, are three reasons for data preprocessing.
- 6) One of the major tasks in data preprocessing is which is responsible for filling in missing values.
- 7) is a data preprocessing task that reduces data volume while maintaining the same or similar analytical results.
- 8) refers to the frequency of occurrence of an itemset, while represents the fraction of transactions that contain the itemset.
- 9) Issues related to classification and prediction include,
- 10) is an example of a data transformation technique.

Question 2: Answer the following questions (10 points)

- A) Given the following data: 25, 20, 22, 10, 3, 5, 7, 27, 35, 30, 37, 40, Smoothing data by bin means using **three** (Equi-depth) bins? (4 Points)
- B) Suppose that minimum and maximum values for the attribute *age* are **15** and **60**, **respectively**. We would like to map age to the range [-1, 1]. By min-max normalization, calculate the normalized value of **35**. (3 Points)
- C) What is the z-score normalized value of **65 kg**, given a mean of **60 kg** and a standard deviation of **18 kg**? (3 points)

Question 3: Answer the following questions (10 points)

The database has five transactions. Let $min\ sup = 60\%$ and $min\ conf = 80\%$

TID	items_bought
T100	{M, O, N, K, E, Y}
T200	{D, O, N, K, E, Y}
T300	{M, A, K, E}
T400	{M, U, C, K, Y}
T500	{C, O, O, K, I, E}

Find all frequent itemsets using Apriori algorithm and **three** Association rules using min. support & min. confidence.

10. Miln's method needs to know at least three initial values of the required function.
11. Runge-Kutta methods provide higher accuracy than Euler's method
12. The while end loop will complete repetitions until a logic statement is true.

Question No. 3: Answer the following questions

(25 marks)

1. Use MATLAB program to perform the following:

- a) Write a MATLAB function to solve the given system of ordinary differential equations numerically over the interval $0 \leq t \leq 200$, and plot the solution to visualize the behavior of the system. (10 marks)

$$\begin{aligned} \frac{dx}{dt} &= 0.1x - 0.02xy, & x(0) &= 40 \\ \frac{dy}{dt} &= 0.01xy - 0.1y, & y(0) &= 9, \end{aligned}$$

- b) Calculate an exact symbolic solution for the ordinary differential equation $y''(x) + 3y'(x) + 2y = 24$, $y(0) = 10$, $y'(0) = 0$ (5 marks)

2. The following data shows the number of ice creams sold based on hours of sunshine. Estimate the sales for 8 hours of sun using the regression line. (10 marks)

X	2	3	5	7	9
Y	4	5	7	10	15

----- End of Questions with my Best Wishes for Success -----

8. The step size h in numerical methods for ODEs is chosen to:
- Minimize computational cost
 - Ensure the solution is exact
 - Balance accuracy and stability
 - Make the problem non-stiff
9. The least squares method is most commonly used in which type of analysis?
- Cluster analysis
 - Regression analysis
 - Time series analysis
 - Descriptive statistics
10. Which of the following MATLAB functions is used to solve stiff ODEs numerically?
- ode45
 - ode23
 - ode15s
 - dsolve
11. In MATLAB, which command is used to solve a symbolic ODE?
- sym
 - ode45
 - dsolve
 - diff
12. The for end loop will repeat a segment of program
- based on a vector counter.
 - while a conditional statement is true.
 - every time the enter key is pressed.
 - indefinitely.
13. Which of the following methods uses the formula
- $$y_{n+1} = y_{n-1} + \frac{h}{3}(f_{n-1} + 4f_n + f_{n+1})$$
- Euler's Method
 - Runge-Kutta Method
 - Adams Method
 - Milne Method

Question No. 2: Determine whether of these statements are true (T) or false (F) (12 marks)

- A correct expected value characterizes modified Euler and Adam methods.
- The least squares method is a statistical technique used to find the best-fitting line or curve for a set of data points.
- The methods of Taylor, Euler and Runge-kutta are called one-step methods for solving nonlinear equations.
- The least squares method is reliable for all types of data.
- In Euler's method, if the step size is too large, accuracy suffers; if too small, computational cost increases unnecessarily.
- The least squares method minimizes the sum of absolute distances between data points and a curve.
- dsolve is part of the Symbolic Math Toolbox, whereas ode45 is built in.
- In multi-step methods, estimates of the solution at a particular step are entirely based on information from more than one step.
- Predictor-corrector methods are self-starting methods.



Faculty of Science
2nd Semester 2024 – 2025
Date: 3/6/2025
Marks: (50)

Department of Mathematics
Scientific Computations 1
(451MC)- 4th level
Time: (2 hours)



Important • No. of pages: 3

Question No. 1: Choose the correct answer

(13 marks)

➤ The following MATLAB code uses the Euler method to solve the differential equation $y'(x) = x y^2 + y$, $y(0) = 1$ on the interval $x = [0, 0.5]$ with step size $h = 0.05$. Answer the following questions numbered 1-5.

1. The Euler method is classified as

- a) One-step method
- b) Multistep method
- c) Midpoint method
- d) Predictor-corrector method

2. The appropriate formula in the position labeled ① is

- a) $n=(b+a)/2$
- b) $n=(b-a)/h$
- c) $n=(b-a)*h$
- d) $h=(b-a)/n$

function y = myeular(h,fx,y,a,b,x0,y0)

```
.....①.....
x(1)=x0;
y(1)=y0;
for i = 1 : n
.....②.....
.....③.....
end
end
```

3. Which of the following expressions is valid in place number ②?

- a) $x(i+1)=x0+(i+1)h$
- b) $x(i+1)=x0+x(i)h$
- c) $x(i+1)=x(i)+h$
- d) $x(i+1)=x(i)+i*h$

4. In the position ③, which of the following is true for calculate $y(i+1)$?

- a) $y(i+1)=y(i)+h*fx(x(i),y(i))$
- b) $y(i+1)=y(i)-fx(x(i),y(i))$
- c) $y(i+1)=y(i)-h*fx(x(i),y(i))$
- d) $y(i+1)=y(i)+(h/2)*fx(x(i),y(i))$

5. What is the correct way to call the function in MATLAB?

- a) myeular (0.5,(xy^2+y),0,0.5,0,1)
- b) myeular (0.05,@(x,y)(x*y^2+y),0,0.5,0,1)
- c) myeular (0.05,@(x,y)(x*y^2+y),0,1,0,0.5)
- d) function(0.05,@(x,y)(x*y^2+y),0,1,0,0.5)

6. What is the primary goal of numerical methods for solving ordinary differential equations (ODEs)?

- a) Find Exact solutions
- b) Find Numerical approximations
- c) Stability analysis
- d) Simplification of equations

7. In a one-step method, the next value of the solution depends on:

- a) Only the initial condition
- b) Only the previous step
- c) Multiple previous steps
- d) An exact solution

٢٤

Department of Mathematics Faculty of Science		قسم الرياضيات كلية العلوم
الامتحان النهائي للفصل الدراسي الثاني ٢٠٢٤/٢٠٢٥ م		
التاريخ: ٢٠٢٥/٦/١ م	علوم رياضيات	للفرقة: الرابعه
الزمن: ساعتان	درجة الامتحان: ٥٠	اسم المقرر الهندسه التفاضليه والتوبولوجي

أولاً: الهندسة التفاضلية (أجب عن اثنان فقط)

١- (أ) عرف المنحني الحلزوني ثم أثبت الشرط الضروري والكافي لكي يكون منحني الفراغ حلزوني هو ان

$$\frac{\chi}{\tau} = \text{مقدار ثابت}$$

(ب) أثبت أن المنحني

$$r(u) = \left\{ u, 2u^2, \frac{8}{3}u^3 \right\}$$

منحني حلزوني وأوجد زاويته.

٢- إذا كانت الصورة العامة للمنحني الناشر هي $\underline{r} = \underline{r} + (C - S)\underline{t}$ أوجد له $t_1, n_1, b_1, \chi_1, \tau_1$

$$\underline{r} = (2ae^u \cos u, 2ae^u \sin u, ae^u)$$

٣- أوجد المعادلات الذاتية للمنحني

ثانياً: التوبولوجي (اجب عن الاسئلة الاتية)

١- (أ) بفرض ان τ_i توبولوجي علي X أثبت ان $\tau_i \cap$ توبولوجي X بينما $\tau_i \cup$ ليس بالضرورة توبولوجي علي X

(ب) نفرض ان $X = \{a, b, c, d, e\}$ وان $\tau = \{X, \phi, \{a\}, \{c, d\}, \{a, c, d\}, \{b, c, d, e\}\}$

توبولوجي علي X و كان $A, B \subset X$ بحيث ان $A = \{a, b, c\}, B = \{a, b\}$

أوجد $A', A^c, \bar{B}, b(B)$

٢- (أ) نفرض ان (X, τ) فراغ توبولوجي وان $A, B \subset X$, أثبت ان

$$A \text{ مجموعة مغلقة } \Leftrightarrow (i) A = \bar{A} \quad (ii) \bar{A} = A \cup A' \quad (iii) b(A) = b(A^c)$$

(ب) أثبت ان $T_2 \Rightarrow T_1 \Rightarrow T_0$ لاي فراغ توبولوجي (X, τ) بينما $T_0 \not\Rightarrow T_1$, $T_1 \not\Rightarrow T_2$

مع تمنياتنا بالنجاح والتوفيق



قسم الرياضيات - كلية العلوم

امتحان نهاية الفصل الثاني 2024 / 2025 م
للفرقة الرابعة علوم شعبة الرياضيات

المادة: نمذجة رياضية (434 ر)
الزمن: 3 ساعات
التاريخ: 6/1 / 2025 م

أجب عن خمسة فقط مما يلي: (العظمي 50 درجة (كل سؤال 10 درجات)

السؤال الأول:

أ- اذكر نبذة مختصرة عما يلي: المحاكاة - النمذجة العلية - النمذجة باستخدام الشرائح
ب- عرف أو بين المقصود بالنمذجة الرياضية وأذكر فقط مراحلها الخمس الأساسية

السؤال الثاني:

استخدم فن النمذجة في استنتاج المعادلة الموجية في بعد واحد وكذلك في
ايجاد معادلة تصف الانتشار الحراري في وسط موضعا بعض الشروط الابتدائية
إذا كان الفيض الحراري معلوم

السؤال الثالث:

استخدم طريقة المربعات الصغرى لايجاد أحسن خط مستقيم يمر بالنقاط الآتية
وذلك بطريقتين :

X=	2	3	4	5	6
Y=	1.1	1.9	2.6	3.4	4.3

السؤال الرابع:

ناقش الحل التقريبي لنظام فيزيائي متذبذب إذا كان تردده الطبيعي دالة في
الزمن.

السؤال الخامس:

ناقش مسألة رايلي - تيلور للاستقرار واستنتج معادلة التشتت

السؤال السادس:

أ- تكلم عن مصادر الخطأ في الطرق العددية وبين كيف يمكن تجنبها بقدر
الإمكان
ب- استعرض اي مشكلة من واقع الحياة وناقش من خلال موضوع النمذجة
مرحلة الاعداد لهذه المشكلة بالتفصيل

WITH MY BEST HOPES

راجعه اد أحمد ماهر

M. H. OBIED ALLAH

$$f_n(x) = \begin{cases} 0, & -1 \leq x \leq 0 \\ nx, & 0 < x \leq \frac{1}{n} \\ 1, & \frac{1}{n} < x \leq 1. \end{cases}$$

- Draw the graph of the functions f_m, f_n , for $m < n$.
- Show that $\{f_n\}_{n \in \mathbb{N}}$ is a Cauchy sequence.
- What is $\lim_{n \rightarrow \infty} f_n$?
- Does $(C[0,1], \|\cdot\|)$ be a Banach space?

Question three: (15 - points) Prove that

- Every Cauchy sequence is bounded.
- The norm $\|\cdot\|: X \rightarrow \mathbb{R}^+$ is continuous.
- By the help of Holder inequality

$$\sum_{i=1}^{\infty} |x_i y_i| \leq \left(\sum_{i=1}^{\infty} |x_i|^p \right)^{\frac{1}{p}} \left(\sum_{i=1}^{\infty} |y_i|^q \right)^{\frac{1}{q}}, \text{ for } (x_i)_{i=1}^{\infty} \in l^p, (y_i)_{i=1}^{\infty} \in l^q,$$

prove that

$$\left(\sum_{i=1}^{\infty} |x_i + y_i|^p \right)^{\frac{1}{p}} \leq \left(\sum_{i=1}^{\infty} |x_i|^p \right)^{\frac{1}{p}} + \left(\sum_{i=1}^{\infty} |y_i|^p \right)^{\frac{1}{p}}.$$

Question four : (10 - points) Prove that

- $(l^2, \langle \cdot, \cdot \rangle)$, is a Hilbert space, where

$$\langle \cdot, \cdot \rangle : l^2 \times l^2 \rightarrow \mathbb{K}, \langle x, y \rangle = \sum_{i=1}^{\infty} \zeta_i \bar{\eta}_i, \text{ for } x = (\zeta_i)_{i=1}^{\infty}, y = (\eta_i)_{i=1}^{\infty} \text{ and } \zeta_i, \eta_i \in \mathbb{R} \text{ (or } \mathbb{C}).$$

- (Cauchy – Schwarz inequality) The absolute value of the inner product of two vectors in an inner product space is less or equal the two norms multiplied. And what is the case in which the equality holds?

May Allah grant you success...

Dr. Shima Ibrahim Moustafa

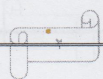

Assiut University		Date : Saturday, 31 May 2025
Faculty of science		Time : 2 hours
Department of Mathematics		Course : Functional Analysis (411 M)
Final Term Exam (2 nd Term) for the 4 th Year Student (Math)		Points : 50

Answer the following questions.

Question one: Choose the correct answer (10 - points)

- i. The non-degeneracy property of a metric d on a non-empty set X is _____.
 - a) $d(x, y) = 0 \Leftrightarrow x = y$
 - b) $d(x, y) = d(y, x)$
 - c) $d(x, y) \geq 0$
- ii. The metric defined by $d(x, y) = \begin{cases} 0, & x = y; \\ 1, & x \neq y. \end{cases} \forall x, y \in X$ is _____.
 - a) usual
 - b) discrete
 - c) indiscrete
- iii. Let $(X, \|\cdot\|)$ be a normed space and d be the metric induced by the norm on X . If $d(x, y) = r$, for $x, y \in X$, then which of the following is false?
 - a) $d(x + a, y + a) = r$
 - b) $d(rx, ry) = r^2$
 - c) $d(rx + a, ry + a) = (r - 1)r$
- iv. Which of the following is not a Banach space?
 - a) Linear space of n -tuples $x = (x_1, \dots, x_n)$ with $\|x\| = \max_{1 \leq i \leq n} |x_i|$.
 - b) Linear space of all 2-summable sequences $x = (\zeta_i)_{i \in \mathbb{N}}$ with $\|x\| = (\sum_{i=1}^{\infty} |\zeta_i|^2)^{\frac{1}{2}}$.
 - c) Linear space of all continuous functions on $[0, 1]$ with $\|f\| = \int_0^1 |f(x)| dx$.
- v. The term Hilbert space stands for a complete _____ space.
 - a) Inner product
 - b) normed
 - c) metric

Question two: (15 - points)

Given the normed space $(C[0, 1], \|\cdot\|)$, where $\|f\| = \left(\int_0^1 (f(x))^2 dx \right)^{\frac{1}{2}}$ and the sequence



15. Which scoring system is commonly used in sequence alignment to assess the quality of an alignment?

- a) PAM and BLOSUM matrices
- b) Dot matrix analysis
- c) Euler's method
- d) Fourier transform

Question No. 1 answers

Question	1	2	3	4	5	6	7	8	9	10	11	12	13	14	15
Answer															

Question No. 2: Determine whether of these statements are true (T) or false (F) (20 marks)

1. Bioinformatics is a theoretical science so the results have not to be experimentally corroborated.
2. Protein 3-D structure provides insights about the function of the protein.
3. A query is a method to retrieve information from the database.
4. Uniprot is a paid protein sequence database.
5. Protein Data Bank (PDB) is a specialized database.
6. Uniprot provide online but not downloading protein sequences.
7. Swiss-Prot is a manually curated section of UniProt.
8. In local alignment, only the regions with the highest density of matches are aligned.
9. FASTA provide a sequence of proteins or DNA in three letter amino acid code.
10. BLASTx translates a nucleotide query sequence into all six reading frames before searching a protein database.
11. Sequence alignment is used to find the evolutionary relationship between sequences.
12. Pairwise sequence alignment is based on a scoring system that assigns positive scores to matching characters and negative scores to mismatching characters or gaps.
13. Secondary databases rely entirely on the data submitted to them by researchers.
14. Dynamic programming methods require more computational time than heuristic methods.
15. Word or k-tuple methods are designed to improve the speed of sequence alignment.
16. Gap penalties are applied to discourage excessive gaps; these include higher penalties for extending a gap and lower penalties for opening it.
17. High E-values in a BLAST result indicate that the alignment is highly significant.
18. The goals of BLAST and FASTA are the same, but their algorithms differ significantly.
19. In vitro technique is a given procedure is performed on the whole living organism itself.
20. Transient interactions are typically involved in signaling pathways.



- Important Remark**
- No. of pages: 3– Solution on the same paper.
 - Put your answers in the table

Question No. 1: Choose the correct answer (15 marks)

- Which of the following databases is primarily used for storing nucleotide sequences?
a) UniProt b) PDB c) GenBank d) Swiss-Prot
- The stepwise method for solving problems in computer science is called _____.
a) Flowchart b) Algorithm c) Procedure d) Sequential design
- Which database is known for high-quality, curated protein sequences?
a) SwissProt b) GenBank c) DDBJ d) KEGG
- BLAST is an algorithm and program to protein sequences.
a) comparing b) downloading c) creating d) eliminating
- The three-dimensional shape of a single-piece peptide chain with a secondary structure is defined by-----.
a) Primary structure b) Secondary structure
c) Tertiary structure d) Quaternary structure
- Uniprot has two main sections-----.
a) Swissprot and DDBJ b) DDBJ and TrEMBL
c) Swissprot and TrEMBL d) GenBank and EMBL
- Which of the following is NOT a type of substitution matrix?
a) PAM matrices b) BLOSUM
c) FASTA d) None of these
- Genes in different species that evolved from a common ancestral gene are called-----.
a) Orthologs b) Analogs c) Paralogs d) Synologs
- Which of these databases focuses on classification of protein structural domains?
a) CATH b) UniProt c) GenBank d) SCOP
- Which algorithm is commonly used for global sequence alignment?
a) BLAST b) FASTA c) Smith-Waterman d) Needleman-Wunsch
- A protein interaction where the individual components are stable and functional on their own is classified as -----.
a) Obligate b) Permanent c) Non-obligate d) Homo-oligomeric
- What type of information is stored in the DDBJ database?
a) Protein family classifications b) Raw nucleotide sequences
c) Protein 3D structures d) Metabolic pathways and enzymes
- Which type of database typically contains more sequences?
a) DNA databases b) Protein databases
c) Both are equal in size d) unannotated Protein databases
- In BLAST, what is a "hit"?
a) A gap in the alignment b) A match found in the database
c) A mismatched base pair d) An error in the alignment process

20

27) Which cipher type is typically faster in processing data

a) Block cipher	c) Both are equally fast
b) Stream cipher	d) Neither is fast

28) What is the main difference between symmetric and asymmetric encryption

a) Symmetric encryption uses two keys, while asymmetric uses one	c) Asymmetric encryption is used for data integrity, while symmetric is not
b) Symmetric encryption is faster than asymmetric encryption	d) Symmetric encryption is used for digital signatures, while asymmetric is not

29) Which of the following is an example of a public key encryption algorithm

a) DES	c) AES
b) RSA	d) Blowfish

30) What is the primary function of encryption in cryptography

a) To compress data for storage	c) To convert plaintext into ciphertext
b) To verify the integrity of data	d) To generate random numbers

31) What is a common method used by viruses to infect a system

a) Exploiting network vulnerabilities	c) Sending spam emails
b) Attaching themselves to executable files	d) Hiding in system memory

32) What is a characteristic feature of a Trojan horse

a) It replicates itself without user intervention	c) It disguises itself as legitimate software to trick users
b) It spreads through email attachments	d) It automatically infects other files on the system

33) How does a worm differ from a virus

a) A worm requires a host file to spread	c) A worm can self-replicate and spread independently across networks
b) A worm is always malicious, while a virus is not	d) A worm is a type of Trojan

34) During the dormant phase, what typically happens to the virus

a) It infects other files immediately	c) It waits for a specific trigger to activate
b) It is automatically deleted by the system	d) It encrypts files on the system

Best wishes

Dr. Yara Raslan

18) In the context of steganography, why is it beneficial to use a larger host image

a) It allows for more data to be hidden without noticeable distortion.	c) It reduces the need for encryption.
b) It simplifies the encoding process.	d) It eliminates the need for a secret message.

19) What does a higher PSNR value indicate in image processing

a) Lower image quality	c) Higher image quality
b) Increased file size	d) More compression artifacts

20) Which is a corrective countermeasure that helps after an attack detected

a) Disabling the affected user accounts	c) Installing a firewall
b) Encrypting sensitive data	d) All of the above

21) What is the primary purpose of padding in block cipher methods

a) To increase the encryption speed	c) To ensure that the plaintext is a multiple of the block size
b) To reduce the size of the ciphertext	d) No correct answer

22) Which of the following is NOT a passive attack

a) Meet-in-the-Middle attack	c) Eavesdropping on a conversation
b) Traffic analysis	d) None of the above

23) Which of the following activities would be classified as a passive attack

a) Sending phishing emails	c) Capturing and analyzing unencrypted data packets
b) Exploiting a vulnerability in software	d) Launching a brute-force attack on a password

24) What is the size of the key matrix used in the Playfair cipher

a) 4x4	c) 5x5
b) 6x6	d) 3x3

25) Which of the following is a common medium used for steganography

a) Text files	c) Images
b) Audio files	d) All of the above

26) What is the primary method of encryption used by block ciphers

a) Encrypts data one bit at a time	c) Encrypts data using variable sizes
b) Encrypts data in fixed-size blocks	d) No correct answer

9) False nonmatch rate in high-security application must be

a) According of problem	c) High rate
b) Low rate	d) Reasonable rate

10) What effect does adding salting have on the time necessary to crack a password

a) No impact on time	c) Makes the password impossible to crack
b) Increases the time needed for cracking	d) Speeds up the cracking process

11) What does the encryption process in a stream cipher generally involve

a) Encrypting data in fixed-size blocks	c) Using a public key for encryption
b) Applying a hash function to the data	d) Combining plaintext with a key stream bit by bit

12) What is the primary benefit of using multi-factor authentication (MFA)

a) It enhances security by requiring multiple forms of verification	c) It simplifies the login process
b) It eliminates the need for passwords	d) It is faster than single-factor authentication

13) Which of the following is an example of "something the user is" in authentication

a) A password	c) A security question
b) A fingerprint or facial recognition	d) A hardware token

14) What is the role of firewalls in defending against active attacks

a) To monitor user behavior	c) To provide user authentication
b) To encrypt data	d) To filter network traffic

15) Why are regular software updates important in security

a) They improve system performance	c) They add new features
b) They patch vulnerabilities	d) They reduce the need for passwords

16) Which of the following features is commonly found in email scanning software

a) User authentication	c) Malware detection
b) Network performance monitoring	d) Data backup

17) What is a potential drawback of not implementing a "Security in Depth" strategy

a) Increased complexity in security management.	c) Higher costs for security solutions.
b) Greater vulnerability to attacks if a single layer is breached.	d) Improved user experience.



Computer Security
Code: رك 453
50 Marks

date: 31/5 /2025
Time: 2 Hour



Q1. Choose the right answer:

50 Marks

1) What type of cipher is RC4.

a) Block cipher	c) Hash function
b) Stream cipher	d) Asymmetric cipher

2) In RC4, what is the purpose of the key-scheduling algorithm (KSA)

a) To generate the initial permutation of the state array	c) To encrypt the plaintext
b) To produce the final ciphertext	d) To decrypt the ciphertext

3) What is the size of the state array used in RC4

a) 128 bytes	c) 56 bytes
b) 512 bytes	d) 256 bytes

4) What does "integrity" in the context of computer security mean

a) Protecting data from unauthorized modification	c) Ensuring that data is available when needed
b) Keeping data confidential	d) Ensuring that systems are user-friendly

5) Which of the following techniques is used to maintain data integrity

a) Hashing	c) Data encryption
b) Firewalls	d) User authentication

6) What does "availability" in computer security refer to

a) Ensuring that data is kept secret	c) Ensuring that data is accurate and reliable
b) Ensuring that systems and data are accessible when needed	d) Protecting data from unauthorized access

7) Which of the following can threaten the availability of a system

a) Denial of Service (DoS) attacks	c) Data breaches
b) authorized access	d) Data corruption

8) Which of the following best describes the relationship between confidentiality, integrity, and availability)

a) They are independent of each other.	c) They are interdependent and collectively ensure security.
b) They are mutually exclusive.	d) They are only relevant in specific contexts.

<p>47- الطريقة المناسبة لكتابة الدالة في المكان رقم ① هي $@(x,y)(x+y)*y$</p>	<p>الكود التالي يستخدم طريقة ملن لحل المعادلة التفاضليه $y'(x) = (x+y)y, y(0)=1, n=4$ وحساب $y(0.4)$</p> <pre> function y=MyMilen(x0,y0,xn,n) f=.....①.....;②..... y(1)=y0;③..... for i=1:n-1 x(i+1)=x(i)+h; y(i+1)=.....④..... end for i = n x(i+1)=x(i)+h; ynew=y(i- 3)+(4*h/3)*(2*f(x(i),y(i)) -3*f(x(i-1),y(i-1))+2*f(x(i- 2),y(i-2))); y(i+1)=y(i- 1)+(h/3)*(4*f(x(i),y(i)) +f(x(i-1),y(i- 1))+f(x(i+1),ynew)); End y=MyMilen(.....⑤.....) </pre> <p>في ضوء ذلك اجب عن الفقرات 47-50</p>
<p>48- في السطر رقم ② نستخدم الشرط $x(0)=x0;$</p>	<p>50- الطريقة الصحيحة لاستدعاء الدالة في المكان رقم ⑤ هي (1,0,4,0.4)</p>
<p>49- الامر المناسب في السطر رقم ③ هو $h=(xn-x0)/n;$ ولحساب $y(i+1)$ في المكان رقم ④ نستخدم $y(i)+h*f(x(i),y(i));$</p>	

مع أجمل أمنياتنا بالتوفيق والنجاح للجميع
د. / فاطمه حسين - د. / إسراء جمال

```

function dx = concentration( t,x,k1,k2 )
x = [-k1.*... ① ..... ; 2.*k1.*x(1) - k2.*x(2)];
end
[t,x] = ... ②...(@ (t,x)concentration(t,x,1,0.5),
[0 10], [1;0]);
... ③ ... (t,x(:,1),'b-*.t,x(:,2),'g-o','linewidth',1);
xlabel('time','fontsize',14)
ylabel('concentration','fontsize',14)
... ④ ..... ('A','B')

```

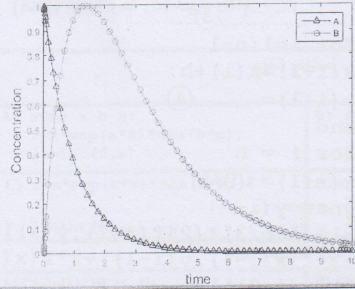

الكود المجاور يستخدم في حل معادلات التفاعل الكيميائي التالية في احدى المفاعلات النووية

$$\frac{dA}{dt} = -k_1A, \quad \frac{dB}{dt} = 2k_1A - k_2B$$

using $k_1 = 1, k_2 = 0.5; A_0 = 1, B_0 = 0, x(1)=A$ and $x(2)=B$ in time range of $[0, 10]$

في ضوء ذلك أجب عن الفقرات الأربعة التالية

36- الرقم ① الموضح في الكود يشير الى الدالة x(1)

37- الرقم ② يشير الى الأمر Dsolve

38- لرسم الحل نستخدم الأمر plot في المكان رقم ③

39- الأمر المناسب في المكان رقم ④ هو label

40- الاستيفاء أو الاستكمال هو استخراج قيمة عددية لدالة صيغتها الرياضية غير معروفة.

41- الدالة ode45 تستخدم في ايجاد حل عددي للمعادلات التفاضليه في برنامج الماتلاب

42- يشمل برنامج Matlab الكثير من التوزيعات المتصلة ولا يحتوي على اي توزيع متقطع

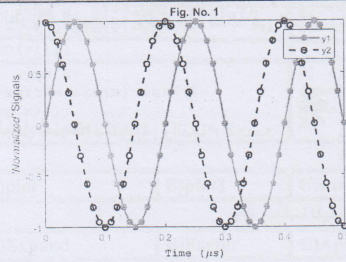

للشكل الموضح بالرسم أجب عن الثلاث فقرات التالية

43- لاضافة عنوان " Fig. No.1" للشكل الموضح بالرسم

نستخدم الأمر title('Fig. No. 1')

44- الامر المستخدم لرسم هذا الشكل في برنامج الماتلاب

t = 0:0.01:0.5;
plot3(t,sin(10*pi*t),'r-*.t,cos(10*pi*t),'k--o')

45- الامر legend('y1','y2') يستخدم لاضافة الشكل التوضيحي على الرسم

46- لحساب النهايه $\lim_{x \rightarrow \infty} \frac{(x+2)^{x+2}}{(x+5)^{2x+5}}$ بلغة الماتلاب نستخدم الكود

```

syms x;
f=(x+2)^(x+2)/(x+5)^(2*x+5); L1=limit(f,x,inf)

```

26- الطريقة المناسبة لاستدعاء الدالة في المكان رقم 4 هي			
A) @x^2*y+y	B) (x,y)y^2*x+y	C) @(x,y)y^2*x+y	D) @(x,y)xy^2+y
27- لحساب النهاية $\lim_{x \rightarrow 0} \frac{\sin x}{x}$ بلغة الماتباتكا نستخدم الكود			
A) Limit[Sin[x]/x, x -> 0]	B) D[Sin(x)/x, {x, 4}]		
C) Limit[Sin[x]/x, x, 0]	D) Lim[sin(x)/x, x -> 0]		
28- لحل معادلة لاغندر التفاضليه $(1-t^2) \frac{d^2x}{dt^2} - 2t \frac{dx}{dt} + n(n+1)x = 0$ بلغة الماتلاب نستخدم الكود			
A) syms t n; x1=dsolve('(1-t^2)*D2x-2*t*Dx+n*(n+1)*x=0','t')			
B) syms t; x1=dsolve('(1-t^2)D2x-2tDx+n(n+1)x=0','t')			
C) x1=solve('(1-t^2)*D2x-2*t*Dx+n*(n+1)*x=0','x')			
D) syms t n; x1=dsolve('(1-t^2)x''-2*t*x'+n*(n+1)*x=0','x')			
x=3;y=5; If[x>y,Print[x],Print[y]]		29- النتيجة المتوقعة للكود المجاور في لغة الماتباتكا	
A) 3	B)3 5	C) 5	D)5 3
30- في لغة الماتباتكا النتيجة المتوقعة عند كتابة الكود {Do[Print[n^2],{n,4}]			
(A) 1 2 3 4	(B) 1 4 9 16	(C) 1 2	(D) 1 4

السؤال الثاني: - (درجة لكل فقرة)

20 درجة

ضع علامة (✓) امام الاجابة الصحيحة وعلامة (x) امام الاجابة الخاطئة:

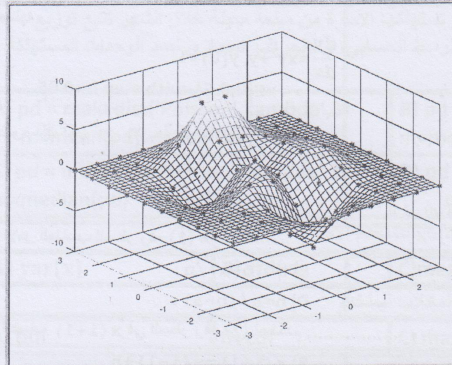

للشكل المجاور اجب عن الثلاث فقرات الآتية:

31- لرسم الشكل المجاور نستخدم الأمر plot

32- الامر interp2 يستخدم للاستكمال أو الاستيفاء في الفراغ

33- لتغيير ألوان الشكل ثلاثي الأبعاد في برنامج الماتلاب نستخدم الأمر colormap

34- لتوليد 3000 من الأرقام العشوائية تتبع التوزيع الطبيعي $\mu = 0.5$ و $\sigma = 1.4$ وحساب الانحراف المعياري نستخدم الكود $x=normrnd(0.5,1.4,3000,1);s=std(x)$

35- في استيفاء كثيرات الحدود بلغة الماتلاب يستخدم الأمر polyfit لتعيين قيم معاملات كثيرة الحدود $p(x) = a_0 + a_1x + a_2x^2 + a_3x^3 + \dots$

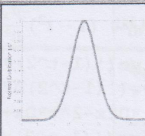
17- يقدم برنامج ماتلاب الدالة..... لعمل استيفاء خطي لمجموعة النقاط المحددة بالمتجهين x و y			
A) simple	B) interp	C) interp1	D) interp2
18- لحساب دالة التوزيع المناسبة لتجربة القاء حجر نرد نستخدم الامر			
A) Poisson(6)	B) unidpdf(1:6,6)	C) normpdf(1:6,6)	D) unifpdf(6)
<pre>x = 0:0.01:40; pd =①.. ('Normal', 'mu', 20, 'sigma', 4) y =②..... (pd,x)③..... (x,y, 'r*') xlabel('x', 'fontsize', 14); ylabel('Normal Distribution pdf');</pre>		<p>الكود المجاور يستخدم لرسم دالة التوزيع للتوزيع الطبيعي لقيم $x = 0:0.01:40$ $\mu=20$ and $\sigma=4$</p> 	
19- الامر المناسب للسطر رقم ① هو			
A) Normalpdf	B) cdf	C) makedist	D) pdf
20- لحساب دالة الكثافة الاحتمالية للتوزيع في السطر رقم ② نستخدم			
A) Norm	B) cdf	C) makedist	D) pdf
21- الامر المناسب للسطر رقم ③ هو			
A) pie	B) plot	C) surf	D) bar
22- يتلقى قسم شرطة في المتوسط 5 مكالمات في الساعة فيكون احتمال تلقى مكالمتين في ساعة مختارة عشوائيا هو			
A) y1 = pdf('poiss',2,5)	B) y1 = pdf(2,5)	C) y1 = ('poiss',2,5)	D) لا توجد اجابه صحيحه
<pre>function y = myeular(h, fxy, a, b, x0, y0)①..... x(1)=x0; y(1)=y0; for i = 1 : n②.....③..... end end myeuler(0.05,.....④....., 0, 0.5, 0, 1)</pre>		<p>الكود الموضح يستخدم طريقه اويلر لاجاد حل المعادلة التفاضليه</p> $\frac{dy}{dx} = xy^2 + y, y(0) = 1,$ $x \in [0, 0.5], \text{ with step } h = 0.05$ <p>في ضوء ذلك اجب عن الاربعة فقرات الآتية:</p>	
23- الامر المناسب للسطر رقم ① هو			
A) n = (b+a) / h;		B) h = (b+a) / n;	
C) n = (b-a) / h;		D) n = h / (b-a) ;	
24- لحساب x(i+1) في السطر رقم ② نستخدم			
A) x(i+1) = x(i) - h		B) x(i+1) = x(i-1) + h	
C) x(i+1) = h - x(i)		D) x(i+1) = x(i) + h	
25- لحساب y(i+1) في السطر رقم ③ نستخدم			
A) y(i+1) = y(i) + h * fxy(x(i), y(i));		B) y(i+1) = y(i) * h * (x(i), y(i));	
C) y(i+1) = y(i) + fxy(x(i), y(i));		D) y(i+1) = y(i) - h * fxy(x(i), y(i));	

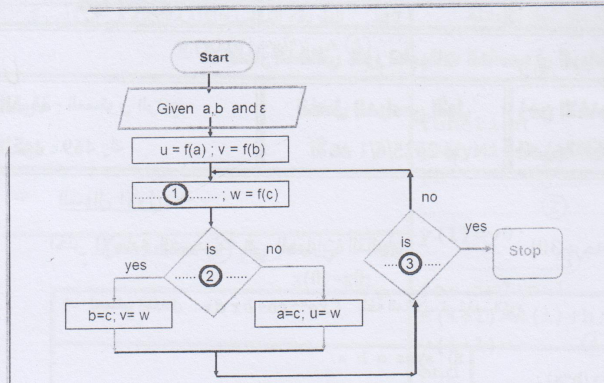

الشكل الموضح بالرسم يوضح خريطه سير العمليات لاستخدام طريقه تصفيف المدى لايجاد جذر تقريبي للمعادله $f(x) = 0$ في الفتره $[a, b]$ بشرط $f(a) f(b) < 0$ بدقه حساب $\epsilon = 0.0001$ في ضوء ذلك اجب عن الثلاث فقرات التاليه :

9- الرقم (1) الموضح على الرسم يشير الى الامر

- A) $c = (a+b)/2$ B) $c = (a-b)/2$ C) $b = (a+c)/2$ D) $b = (a-c)/2$

10- الرقم (2) الموضح على الرسم يشير الى السؤال عن.....

- A) $u+w > 0$ B) $u * w > 0$ C) $u * w < 0$ D) $u-w < 0$

11- الرقم (3) الموضح على الرسم يشير الى السؤال عن

- A) $(b+a)/2 > \epsilon$ B) $(b-a)/2 > \epsilon$ C) $(b+a)/2 < \epsilon$ D) $(b-a)/2 < \epsilon$

12- إذا كان من المعلوم أن عدد الوحدات التي تستهلكها الأسرة من سلعة معينة خلال الشهر تتبع توزيع بواسون بمتوسط 3 وحدات شهريا، لحساب الوسط الحسابي، والانحراف المعياري لعدد الوحدات المستهلكة بلغة الماتلاب نستخدم الكود

- A) `pd = makedist('Poisson','lambda',3)`
`m=mean(pd) s=std(pd)`
- B) `pd = distmake('Poisson','lambda',3)`
`m=mean(pd) s=std(pd)`
- C) `pd = makedist('Poisson','lambda',3)`
`m=median(pd) s=var(pd)`
- D) `pd = dist('Poisson','lambda',3)`
`m(pd) std(pd)`

13- لحساب التباين للمتجه $x = [4 \ 8 \ 20 \ 2 \ 7 \ 10]$ نستخدم الأمر

- A) `var(x)` B) `std(x)` C) `mean(x)` D) `median(x)`

14- لحساب دالة التوزيع التراكميه $F(x)$ في الماتلاب نستخدم

- A) `pdf` B) `cdf` C) `makedist` D) `distmake`

15- الدالة تعطي القيمه y لكثيره الحدود التي معاملاتها a عند الاحداثي x

- A) `randam(a,x)` B) `polyfit(a,x)` C) `polyval(a,x)` D) `polyval(a,y)`

16- لرسم السطح الذي معادلته $z = \sin(x^2 - y^2)$ بحيث $(x,y) \in [-1,1] \times [-1,1]$

- A) `z=sin(x.^2-y.^2); surf(x,y,z)`
- B) `[x,y]=meshgrid(-1:.1:1); z=sin(xy) surfc(x,y,z)`
- C) `[x,y]=meshgrid(-1:.1:1); z=sin(x.^2-y.^2); surfc(x,y,z)`
- D) `[x,y]=meshgrid(-1:.1:1); z=sin(x.^2-y.^2); plot(x,y,z)`

Department of Mathematics		قسم الرياضيات
Faculty of science		كلية العلوم
الاختبار النهائي لقرر تطبيقات الحاسب في الرياضيات		
زمن الاختبار : ساعتان	الفصل الدراسي الأول	الفرقة : المستوى الرابع
الدرجة الكلية: 50 درجة	الأهد 2025/6/1 م	الكود : 469 رك

السؤال الأول: -

اختر الإجابة الصحيحة في العبارات التالية: (30 درجة لكل فقرة درجة واحدة)

1- لحساب التكامل $\int x e^{ax} \cos bx \, dx$ بلغة الماتلاب نستخدم الكود			
A) syms a b x; f=x*exp(a*x)*cos(b*x); I1=int(f,x)	B) syms a b x; f=x*exp(ax)*cos(bx); I1=int(f,x)		
C) f=x*exp(a*x)*cos(b*x); I1=int(f,x)	D) syms x; f=x*exp(a*x)*cos(b*x); I1=int(f,x)		
2- لحساب التفاضل الرابع للدالة $(\sin x)^{10}$ بلغة الماتلاب نستخدم الكود			
A) D[Sin x ^10, {x, 4}]	B) D[Sin(x)^10, {x, 4}]		
C) Diff[Sin x ^10, {x, 4}]	D) syms x; D[Sin x ^10, x, 4]		
3- لايجاد حل المعادلة الأتيه $e^{2x}-2x-1=0$ نستخدم الأمر			
A) solve	B) sol	C) roots	D) polyval
4- لحساب التكامل $\int \frac{1}{x^3+1} dx$ بلغة الماتلاب نستخدم الكود			
A) Integrate[1/(x^3 + 1), x]	B) Int[1/(x^3 + 1), x]		
C) integrate(1/(x^3 + 1), x)	D) syms x; Int[1/(x^3 + 1), x]		
5- لحساب تفاضل الدالة $y(x) = \sqrt{x \sin x \sqrt{1 - e^x}}$ بلغة الماتلاب نستخدم الكود			
A) syms x; D1=simple(diff f); f=sqrt(x*sin(x)*sqrt(1-exp(x)));	B) f=sqrt(xsin(x)*sqrt(1-exp(x))); D1=simple(diff(f))		
C) syms x; f=sqrt(x sin(x) sqrt(1-exp(x))); D1=simple(diff(f))	D) syms x; f=sqrt(x*sin(x)*sqrt(1-exp(x))); D1=simple(diff(f))		
6- الأمر المستخدم لرسم سطح في الفراغ بلغة الماتلاب			
A)plot	B)plot3	C)surf	D)Plot3D
7- لتحليل كثيرة الحدود $x^2 - 2x + 3$ في برنامج الماتلاب نستخدم الأمر			
A)Expand	B)Factor	C)Apart	D)Simplify
			8- عند كتابه الكود الموضح في برنامج الماتلاب تكون قيم a,b الناتجه
			{a, b}={1, 1}; {a++, ++b}
A) {1,2}	B) {2,1}	C) {1,1}	D) {2,2}

a. longest sub-string Method	b. Table-Driven Method	c. Symbolic Method	d. Ad hoc Methods
14) The regular expression corresponding to the following DFA where $\Sigma = \{b, notb\}$ is			
a. $(notb)^* (notb)^*b(notb)^*$	b. $(notb)^*b(notb)^*$	c. $(notb b notb)^*$	d. $(notb b notb)^*(b \epsilon)$
15) Which of the following is a key characteristic of Pascal comments?			
a. They are enclosed within /* and */.	b. They start with two hyphens -- and extend to the end of the line.	c. They are enclosed within curly braces {}.	d. They use a semicolon ; as a prefix.

End Questions

Best Wishes

Dr. Amal Abdelazim

5) Which grammar will produce the following syntax tree where a and b are terminals			
a. $E \rightarrow SbE \mid S$ $S \rightarrow a$	b. $E \rightarrow abE \mid S$ $S \rightarrow b$	c. $E \rightarrow EbE \mid E$ $S \rightarrow a$	d. $E \rightarrow SaE \mid S$ $S \rightarrow b$
6) What is a disambiguating rule?			
a. A rule that simplifies grammar completely	b. A rule that specifies which parse tree is correct in ambiguous cases	c. A rule that removes all grammar rules	d. A rule that complicates the grammar unnecessarily
7) What does the regular expression $(\alpha \beta)(\alpha \beta \gamma)^*$ ensure in the generated strings?			
a. The string does not start with 'y'	b. The string contains only one 'y'	c. The string starts with 'y'	d. The string has an even number of 'y's
8) It takes the intermediate code and generates code for target machine			
a. Semantic analyzer	b. Source code optimizer	c. Code generator	d. Target Code Optimizer
9) Collect separate object files into a directly executable file			
a. Interpreters	b. Linkers	c. Debuggers	d. Assembler
10) Which of the following strings would NOT be matched by the expression $((a c)^*b(a c)^*b(a c)^*)^*$?			
a. "bcbb"	b. "aacbb"	c. "acbbac"	d. None of the mentioned
11) Choice among alternatives in a regular expression r , indicated by			
a. meta-character	b. meta-character *	c. brackets ()	d. None of the mentioned
12) In term of generated languages by regular expression r , the concatenation set of strings S1S2 is:			
a. the set of strings of S1 appended by all the strings of S2	b. the set of strings of S2 appended by all the strings of S1	c. the set of strings of S1 appended by the first string only of S2	d. Both a and b
13) Because of the complexity of regular expression, the comments will be handled byin actual scanners.			

Answer the following questions (Exam from 3 pages)

Question 1: Determine if the statements below True or False. (20 points)

- 1) In the compilation process, tokens are the input to the scanner phase. ()
- 2) The parser function takes the sequence of tokens produced by the parser as its input and produce syntax tree as its output ()
- 3) Terminals are the most general structure listed first in the grammar rules. ()
- 4) The string $$$$bbb$ can be generated from the single grammar rule $E \rightarrow \$Eb | b$ ()
- 5) Changing grammar can help eliminate ambiguity. ()
- 6) **Editors** execute the source program immediately rather than generating object code ()
- 7) The regular expression $b|ac^*$ is interpreted according to Precedence of Operation as: $(b|a)(c)^*$ ()
- 8) A regular expression r cannot contain special characters such meta symbols. ()
- 9) From the regular expressions basic ϵ denotes the empty string, by $L(\epsilon) = \{ \}$ ()
- 10) The string $abcaabb$ can be generated from the following grammar rule:
 $S \rightarrow aSb|BS|a$ ()
 $B \rightarrow b|c$ ()

Question 2: Choose the Correct answer. (30 points)

1) The basic data structure of Syntax analysis is:			
a. Parse Tree	b. Tokens	c. Regular Expression	d. Grammar
2) Which function is called by the parser to obtain tokens as needed?			
a. scanToken()	b. parseToken()	c. getToken()	d. nextToken()
3) In a single-pass compiler, the syntax tree is:			
a. Constructed explicitly and stored in memory	b. Not required at all	c. Represented implicitly by parser actions	d. Built during code generation phase only
4) If $L(G) = \{x, x!x, x!x!x, \dots\}$ then, the grammar G which has single grammar rule generates the language L:			
a. $S \rightarrow S! x$	b. $S \rightarrow !Sx x$	c. $S \rightarrow !S x$	d. $S \rightarrow S!x x$

3. According to Flynn's Taxonomy, which category does a standard single-core personal computer fall into?

- a) SIMD (Single Instruction, Multiple Data)
- b) MIMD (Multiple Instruction, Multiple Data)
- c) MISD (Multiple Instruction, Single Data)
- d) SISD (Single Instruction, Single Data)

4. Which of the following best describes concurrent computing?

- a) Many calculations or processes are executed simultaneously using multiple processing units.
- b) Tasks are divided across multiple computers connected via communication links.
- c) Multiple tasks appear to run simultaneously by rapidly switching between them, which can occur on a single-core processor.
- d) It strictly requires multicore processors for execution.

5. When switching execution from thread T1 to thread T2 within the same process, what happens to the address space?

- a) The address space is saved for T1 and a new one is loaded for T2.
- b) The address space remains the same.
- c) A portion of the address space is swapped.
- d) The operating system allocates a new address space for T2.

Question 4) (10 Points) Answer the following questions:

- a) What are the problem of using Disable Interrupt approach to build locks mechanisms?
- b) Explain Compare-And-Swap approach to build locks mechanisms. Write Pseudo code for lock and unlock functions for this approach

Question 5) (10 Points)

Consider the first attempt at creating a lock using a simple flag variable with load/store operations, as follows

<pre>void lock(lock_t *mutex){ while (mutex->flag == 1) ; mutex->flag = 1; }</pre>	<pre>void unlock(lock_t *mutex) { mutex->flag = 0; }</pre>
--	---

Assume mutex->flag is initially 0. Provide a step-by-step trace of execution for two threads, Thread A and Thread B, both attempting to call lock()

It always seems impossible until it is done
Dr. Ahmed Hosny - 2025

٦٥

Notes:

- Cheating or Trying to Cheat may disqualify you from the course.
- ChatGPT or any AI tool is not allowed in this exam. Use only HI (Human Intelligence)!

Question 1) (10 Points) You are given a simple C program that calculates the dot product of two large vectors A and B, each of size N, using a single loop. The program looks like this:

```
long long dot_product = 0;
for (int i = 0; i < N; i++) {
    dot_product += A[i] * B[i];
}
printf("Dot Product: %lld\n", dot_product);
```

Write a C program that performs the same dot product calculation but does so in parallel using M threads (assume $M < N$ and N is divisible by M for simplicity). Your program should include the main function and the worker thread function. Each thread should handle a part of the computation, and the final result should be the correct dot product of the two vectors. Make sure the partial results from all threads are safely combined into a single final result.

Question 2) (10 Points) A high-throughput distributed system has multiple worker threads that independently process incoming tasks. Each worker thread needs to log significant events (e.g., task completion, errors) to a central, shared log file. It is crucial that log messages from different threads are not interleaved in the file (i.e., each message must appear as a contiguous block).

Describe how mutex locks can be used to ensure that log messages are written to the shared file atomically by each thread. **Provide a pseudo code to explain your answer.**

Question 3) (10 Points) Answer the following MCQs

1. What is a key difference between threads and processes?
a) Processes share the same address space, while threads do not.
b) Threads have their own individual address spaces, while processes share one.
c) Threads share the same address space, while processes have separate address spaces.
d) Both threads and processes always have separate address spaces.

2. What are the two primary use cases for employing threads in programming?
a) To decrease software complexity and reduce memory usage.
b) For parallelism to speed up computation and to avoid blocking by overlapping I/O with computation.
c) To simplify debugging and guarantee deterministic execution.
d) To ensure data integrity and enhance program security.

Answer Only Five Questions of the Following (10 Marks per Question)

- 1) A) Prove that the eigenvalues of square matrix A and of the matrix $T^{-1} A T$ is a regular square matrix, are the same.

B) Use Le Verier- Faddeev method to find the characteristic equation of the matrix:

$$A = \begin{pmatrix} 1 & 2 & -1 \\ 1 & 0 & 1 \\ 4 & -4 & 5 \end{pmatrix},$$

then find the eigenvalues.

- 2) For the equation: $y' = -5y, 0 \leq x \leq 1, y(0) = 1$ (Exact solution $y = e^{-5x}$).

A) Find an upper bound of the error at $x = 1$ in terms of the step size h .

B) Solve the difference equation which results from Euler's method.

C) Compare the bound obtained from (A) with the absolute error as obtained from (B) at $x = 1$ for $h = 0.1$.

- 3) Solve the following linear system by the method of iteration:

$$x_1 + 0.3x_2 + 0.4x_3 = 1.7,$$

$$0.2x_1 + x_2 + 0.4x_3 = 1.6,$$

$$0.1x_1 + 0.4x_2 + x_3 = 1.5.$$

A) Show that the process of iteration converges to the solution of the above system

B) What is the maximum error after performing 15 iterations.

- 4) A) Derive Adam Bashforth's method of order 4 to solve the initial value problem

(IVP): $y' = f(x, y), \quad y(x_0) = y_0.$

B) Apply the driven method (A) to find $y(1.2)$ and $y(1.5)$ for the IVP:

$$y = -x^3 y, \quad y(0) = 1, y(0.3) = 0.99798, y(0.6) = 0.96812, y(0.9) = 0.84872$$

- 5) A) State the Finite Differences formulas for $y', y'',$ and $y^{(iv)}$.

B) Use the formulas stated in (A) to solve the boundary value problem (BVP):

$$y'' + 4y = 0, \quad y(0) = 0, \quad y(1) = 1 \text{ use } h = 0.25.$$

- 6) A) Derive (Predictor- Corrector) Milne's method to solve the initial value problem

(IVP): $y' = f(x, y), \quad y(x_0) = y_0.$

B) Apply the derived method (A) to find $y(0.4)$ for the IVP:

$$y = x^2 - y, \quad y(0) = 1, y(0.1) = 0.90516, y(0.2) = 0.82127, y(0.3) = 0.74918.$$

-
- 41) How many types of join in SQL
- A. 1
 - B. 2
 - C. 3
 - D. 4
- 42) The join is used in MapReduce
- A. theta
 - B. left
 - C. right
- 43) what is the meaning of the next sentence $A[4 : 5]$, where A is an array.
- A. the elements from 4 to 5 positions
 - B. The element in row 4 and column 5
 - C. The element in row 4 and column 5
- 44) what is the meaning of the next sentence $A[4 : 5]$, where A is an array.
- A. the elements from 4 to 5 positions
 - B. The element in row 4 and column 5
 - C. The element in row 4 and column 5
- 45) The join is used in MapReduce
- A. theta
 - B. left
 - C. right
- 46) The primary/Backup can solve the network partition.
- A. True
 - B. False
- 47) The Raft algorithm can solve the network partition.
- A. True
 - B. False
- 48) GO routine makes a function as a thread
- A. True
 - B. False
- 49) The results of VIEW are stored in new table
- A. True
 - B. False
- 50) The numeric datatype used in the currency is
- A. Decimal
 - B. Float
 - C. Double
 - D. Int

End of Questions
Best Wishes
DR. Ibrahim Elsemman

- B. False
- 31) GO routine makes a function as a thread
- A. True
 - B. False
- 32) In Linux, to make an environmental variable, we use the command **export DBUSER=username**
- A. True
 - B. False
- 33) Primary/Backup and RAFT can play a main role in from/in distributed Databases
- A. Insert, update, or delete
 - B. Insert
 - C. query
 - D. Update or delete
- 34) MapReduce can play a main role in from/in distributed Databases
- A. Insert, update, or delete
 - B. Insert
 - C. query
 - D. Update or delete
- 35) **primary/Backup tolerance has non-deterministic events**
- A. True
 - B. False
- 36) **The next code makes two processes A and B**
- ```
func main() {
 go processB()
 go processA()
}
```
- A. True
  - B. False
- 37) **The next code makes two processes A and B**
- ```
func main() {  
  go processB()  
  go processA() }  
}
```
- A. True
 - B. False
- 38) **if two replicas call gettime() they may get different answers many variants of state machine replication.**
- A. True
 - B. False
- 39) **RAFT fault tolerance cannot overcome the network partition.**
- A. True
 - B. False
- 40) **RAFT fault tolerance cannot overcome the network partition.**
- A. True
 - B. False

- B. MapReduce
 - C. Reduce
 - D. Map
- 24) What is C?
- A. Group by
 - B. MapReduce
 - C. Reduce
 - D. Map

Assume you have the next figure that represents Hadoop.

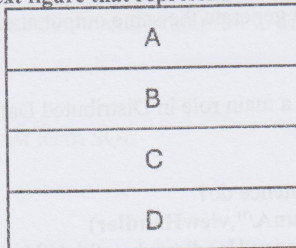

- 25) What is A?
- A. Hadoop distributed file system
 - B. MapReduce Engine
 - C. HiveQL
 - D. Analysis tools and Machine Learning
- 26) What is B?
- A. Hadoop distributed file system
 - B. MapReduce Engine
 - C. HiveQL
 - D. Analysis tools and Machine Learning
- 27) What is C?
- A. Hadoop distributed file system
 - B. MapReduce Engine
 - C. HiveQL
 - D. Analysis tools and Machine Learning
- 28) What is D?
- A. Hadoop distributed file system
 - B. MapReduce Engine
 - C. HiveQL
 - D. Analysis tools and Machine Learning
- 29) Which model used in big companies?
- A. Client/Server
 - B. Master/slave
 - C. peer-peer
 - D. Mobile applications
- 30) There are bugs in Hardware.
- A. True

- B. null
 - C. NULL
 - D. nil
- 17) Which statements can be used to define variable myDB as SQL database?
- A. var myDB *sql.DB
 - B. var myDB sql.DB
 - C. myDB = *sql.DB
 - D. myDB = sql.DB
- 18) The GO program can generate the same output at each run?
- A. True
 - B. False
- 19) MapReduce can play a main role in Distributed Database?
- A. True
 - B. False
- 20) What can the next sentence do?
http.HandleFunc("/runA/",viewHandler)
- A. call the function viewHandler when the URL contains runA
 - B. call the function runA when the GO program receives input through HTTP
 - C. Listen to HTTP messages to the GO program
 - D. Search for runA in the URL
- 21) In Raft, each node has state(s).
- A. 2
 - B. 3
 - C. 4
 - D. 5

Assume you have the next figure

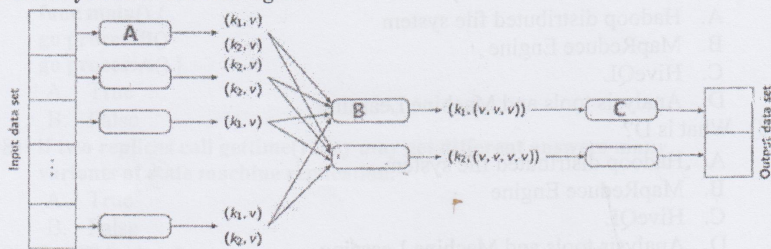

- 22) What is A?
- A. Group by
 - B. MapReduce
 - C. Reduce
 - D. Map
- 23) What is B?
- A. Group by

~

- D. Set
- 7) **Is the next command correct**
CREATE TABLE HeadOfState(
ID INT NOT NULL,
LastName CHAR(30) NOT NULL,
FirstName CHAR(30) NOT NULL);
- A. True
B. False
- 8) In Go lang, we can use the function `fmt.print` to print in the consol
- A. true
B. false
- 9) All programmers must learn SQL
- A. True
B. False
- 10) FOREIGN KEY is used to implement the one-to-many relationship.
- A. True
B. False
- 11) In GO Lang, which functions that can print in http stream.
- A. `cout`
B. `println`
C. `fmt.Fprintf`
D. `fmt.Fprintf`
- 12) In GO, the used library to connect with MySQL is `github.com/go-sql-driver/mysql`
- A. True
B. False
- 13) In windows, how to make an environmental variable X?
- A. `export X=ali`
B. `set X=ali`
C. `path X ali`
D. `path x=ali`
- 14) In GO lang, the two machines can communicate between them with remote procedure call.
- A. True
B. False
- 15) In GO lang, the two machines can communicate between them with TCP.
- A. True
B. False
- 16) `if Err !={ // print error in the consol }`
- A. ERROR



Assiut University

Faculty of
Sciences



Faculty of Computers and
Information

Lecture member: 1. Dr Ibrahim Elsemman	Final Exam of: موضوعات مختارة 2	Level: 4 , Semester:2 Academic Year: 2024/2025 Exam date: 20/05/2025
Total marks: 50 marks.	Pages 6 pages	Exam time: 2 hour

Answer the following questions:

- 1) In GO, to open a file, we need to import the package

 - A. fmt
 - B. os
 - C. io
 - D. log

- 2) In GO, the block size of SHA256 is

 - A. 16
 - B. 32
 - C. 64
 - D. 128

- 3) The Package sha256 implements only the SHA256 hash algorithm.

 - A. True
 - B. False

- 4) **Where is the error line?**

```
func main() {  
h := sha256.New()  
h.Write(byte("hello world\n"))  
fmt.Printf("%x", h.Sum(nil))  
}
```

 - A. h := sha256.New()
 - B. h.Write(byte("hello world\n"))
 - C. fmt.Printf("%x", h.Sum(nil))
 - D. func main() {

- 5) An integer attribute is four bytes; how many numbers can be stored in this attribute?

 - A. 2^8
 - B. 2^{16}
 - C. 2^{24}
 - D. 2^{32}

- 6) To store a video in the table, we use the datatype

 - A. Varchar
 - B. char
 - C. Blob

 قسم الرياضيات كلية العلوم	المقرر : بحوث عمليات (2) 426 الفرقة : المستوى الرابع علوم الزمن : 3 ساعات التاريخ : الاربعاء 5/1/2025 الدرجة : 50 درجة	جامعة اسيوط كلية العلوم قسم الرياضيات امتحان الفصل الثاني للعام الجامعي 2024-2025
	أجب عن الأسئلة الآتية: كل سؤال (10 درجات)	

السؤال الأول: (أ) برهن أن الشرط الكافي لكي تكون الدالة نهاية عظمى او صغرى عندما n تكون زوجية (حيث تكون المشتقات الجزئية للدالة مساوية للصفر) هو عندما $f^{(n)}(x^*) < 0$ نهاية عظمى و عندما $f^{(n)}(x^*) > 0$ نهاية صغرى.

(ب) مستخدما مصفوفة الهسين H أوجد نقط النهايات العظمى والصغرى للدالة

$$f(x) = x_1 + 2x_3 + x_2 x_3 - x_1^2 - x_2^2 - x_3^2$$

السؤال الثاني: (أ) مستخدم الشرط الضروري من الرتبة الثانية حل المسألة التالية

$$\text{Min } f(x) = (x_1 - 1)^2 + x_2$$

$$\text{s.t. } x_1 - x_2^2 \leq 0$$

(ب) أوجد مصفوفة الهسين للدالة $f(x) = x_2^2 x_3 + x_1 e^{x_3}$ عند النقطة $(2, -1, 3)$.

السؤال الثالث: أستخدم طريقة مضروبوات لاجرائج في حل المشكلة التالية

$$\text{Max } f(x_1, x_2) = x_2^2 x_1 \quad \text{s.t.} \quad g(x_1, x_2) = 2x_2^2 + 2x_1 x_2 - 36 = 0$$

ثم طبق الشرط الكافي لمعرفة ان النقطة نهاية عظمى .

السؤال الرابع: (أ) بأستخدام طريقة خطوة الانحدار الشديد أوجد القيمة الصغرى للدالة

$$f(x) = x_1^2 + x_2^2 - 2x_1 x_2 \quad \text{حيث } (x_1^0, x_2^0) = (1, 0)$$

(ب) بأستخدام طريقة تعديل المتغيرات أوجد القيمة الصغرى للدالة

$$f(x) = 25x_1^2 + x_2^2 \quad \text{at } (x_1^0, x_2^0) = (1, 1)$$

السؤال الخامس: (أ) بأستخدام طريقة نيوتن أوجد القيمة الصغرى للدالة $f(x) = 3x_1^2 + 2x_2^2 + 2x_1 x_2 + 7$

$$\text{عندما } (x_1^0, x_2^0) = (5, 10)$$

(ب) استخدم دالة الجزاء (penalty) أوجد حل المسألة التالية

$$\text{Min } f(x) = (x_1 - 1)^2 + (x_2 - 2)^2$$

$$\text{s.t. } g(x) = x_1 + x_2 - 4 = 0$$

مع تمنياتي بالنجاح والتوفيق

د/ مصطفى علي الخطيب

**Answer the following questions:**

(10 marks for any question)

1-a) Suppose that $X \sim U(0,1)$, compute the PDF of $Y = -\ln X$.

b) Let X_1, X_2, \dots, X_n be a random sample of size n from the Poisson distribution with parameter θ , compute the moments estimate of θ .

2-a) Let $X \sim N(\mu, \sigma^2)$, find the PDF of $W = e^X$.

b) If $X \sim N(0,1)$ prove that the random variable $W = X^2$ is distributed as chi-square distribution with one degree of freedom ($W = X^2 \sim \chi^2(1)$).

3-a) Let X_1, X_2, \dots, X_n be a random sample of size n from the Beta distribution with PDF $f(x) = \theta x^{\theta-1}$, $0 < x < 1$:

(i) compute the maximum likelihood estimate of θ .

(ii) construct a $100(1-\alpha)\%$ CI for the parameter θ .

b) A random sample of size 16 is drawn from a normal population $N(\mu, 9)$ gives $\bar{x} = 20$, compute a 99% CI for the population mean μ , ($Z_{0.995} = 2.58$).

4) Let X_1, X_2, \dots, X_n be a random sample of size n from a normal distribution $N(\mu, \sigma^2)$:

(i) prove that $\bar{X} \sim N(\mu, \frac{\sigma^2}{n})$

(ii) show that $\frac{(n-1)S^2}{\sigma^2} \sim \chi^2(n-1)$, $S^2 = \frac{1}{n-1} \sum_{i=1}^n (x_i - \bar{x})^2$

(iii) for a random sample of size 25 and $\bar{x} = 80$ from the $N(\mu, 36)$, test $H_0: \mu = 83$ against $H_1: \mu \neq 83$ at a significant level, ($\alpha = 0.05$, $Z_{0.975} = 1.96$).

5-a) State and prove the central limit theorem.

b) Let X_1, X_2, \dots, X_n be a random sample of size n from a population with CDF $F(x; \theta, \beta) = 1 - (1+x^\beta)^{-\theta}$, $x > 0$,

Construct a $100(1-\alpha)\%$ CI for the parameter θ when β is known.

With my best wishes
Professor Zeinuh Jaheen

Z. Jaheen

industry	U nits	industry=[4 8 20 2 7 10];(1).....(industry); title('Pie char showing percentage of GDP per industries');
Cement	4	labels =
Textile	8	{'Cement', 'Textile', 'Chemical', 'Telecom', Banking'};
Software	2(2).....(labels)
Chemical	0	
Telecom	2	
Banking	7	
	1	
	0	

٣٨- أي مما يلي يكون مناسباً للأمر رقم ①؟

٣٩- أي مما يلي يكون مناسباً للأمر رقم ②؟

٤٠- لتحليل مقدار جبري الي كسوره الجزئية في لغة الماتيماتيكا نستخدم الامر

- (A) Expand (B) Apart (C) Factor (D) Num

السؤال الثاني : مقالي (١٠ درجات)

استخدم الماتيماتيكا :

١) ايجاد جذور المعادلة $x^2 + 5x + 6 = 0$

٢) حساب النهاية $\lim_{n \rightarrow \infty} \left(1 + \frac{1}{n}\right)^n$

٣) حساب النفاضل الرابع للدالة $(\sin x)^{10}$

٤) لايجاد حل المعادله الآتية $e^x - 2x - 1 = 0$

٥) لحساب التكامل $\int \frac{1}{x^3+1} dx$

انتهت الاسئلة بالتوفيق و النجاح د شيرين علي محمد السيد

لحساب النهاية $\lim_{x \rightarrow 0} \frac{1 - \cos x}{x^2}$ بلغة الماتباتيكا نستخدم الكود
 $\text{Limit}[(1 - \text{Cos}[x])/x^2, x \rightarrow 0]$

A) TRUE B) FALSE

إذا كان الكود التالي يستخدم لرسم السطح الموضح في الفراغ في ضوء ذلك أجب عن الثلاث فقرات الآتية

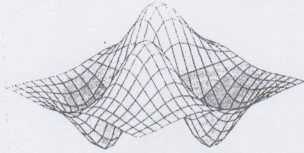

(A) grid off

(B) grid on

(A) plot3D

(B) surfc

(A) mapcolor

(B) plot3DColor

٣٤- نستخدم الأمر ① لتعريف قيم المتغيرين x, y :

(C) mesh (D) meshgrid

٣٥- لرسم هذا السطح في برنامج الماتلاب نستخدم الأمر ② :

(C) surf (D) plot3

٣٦- الأمر ③ المناسب لتغيير ألوان الشكل ثلاثي الأبعاد هو

(D) Colormap (C) plotColor

٣٧- عند كتابة الكود التالي في الماتباتيكا

$\{a, b, c\} = \{1, 1, 1\};$

$a += 6$

$b -= 1$

$c = 2$

المخزنة في الذاكرة a, b, c تكون قيم

(A) $a=6, b=1, c=0$ (B) $a=7, b=0, c=2$ (C) $a=7, b=1, c=2$ (D) $a=6, b=1, c=2$

* الكود الموضح يستخدم لتمثيل البيانات الموضحة في الجدول لتركيز الصناعات المختلفة في دولة ما كما بالشكل في ضوء

Pie char showing percentage of different industries

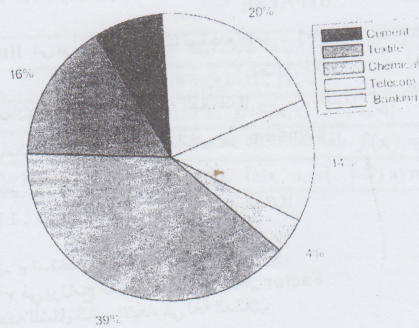

تين:

نلك أجب عن الفقرتين الآتي

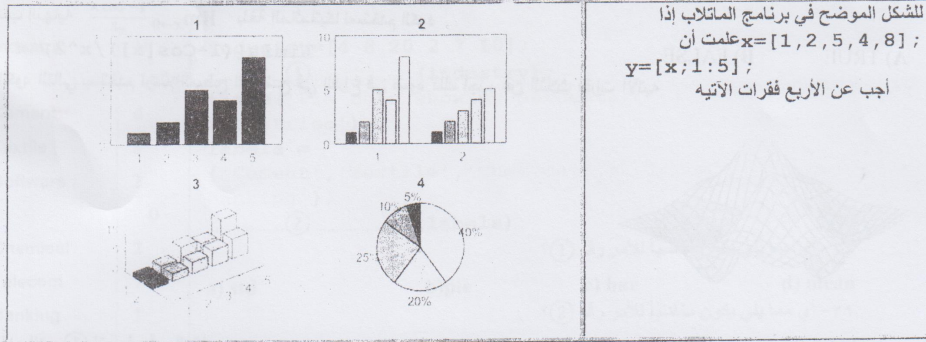

١٩- الأمر المناسب لرسم الشكل رقم ① هو			
bar(x) (D)	pie(y) (C)	bar3(y) (B)	barh(y) (A)
٢٠- لرسم الشكل رقم ②			
bar(x) (D)	pie(y) (C)	bar3(y) (B)	barh(y) (A)
٢١- الأمر المناسب للرسم البياني في ثلاثة أبعاد الشكل رقم ③ هو			
bar(x) (D)	pie(y) (C)	bar3(y) (B)	barh(y) (A)
٢٢- الأمر المستخدم للرسم الشكل ④ هو			
bar(x) (D)	pie(x) (C)	bar3(y) (B)	barh(y) (A)
<pre>{a, b, c} = {1, 1, 1}; a += 6 b -= 1 c *= 2</pre>		٢٣- عند كتابة الكود المجاور في برنامج الماتلاب تكون قيم a,b,c المخزنة في الذاكرة	
a=7,b=0,c=2 (D)	a=6,b=1,c=0 (C)	a=7,b=1,c=2 (B)	a=7,b=0,c=4 (A)

- ٢٤- لحساب التكامل $\int_0^{\infty} \frac{\cos x}{\sqrt{x}} dx$ بلغة الماتلاب نستخدم الكود

```
syms x; I1=int(cos(x)/sqrt(x), x, 0, inf)
```



A) TRUE B) FALSE
- ٢٥- لحساب النهاية $\lim_{n \rightarrow \infty} \left(1 + \frac{1}{n}\right)^n$ في برنامج الماتلاب نستخدم الأمر

```
Limit[(1+1/n)^n, n -> inf]
```

A) TRUE B) FALSE
- ٢٦- الأمر `Dsolve` يستخدم لحل المعادلات التفاضلية في لغة الماتلاب
A) TRUE B) FALSE
- ٢٧- الأمر المستخدم لإيجاد مجموع المتسلسلة $\sum_{i=1}^{30} \frac{1}{x^5}$ بلغة الماتلاب هو `symsum`
A) TRUE B) FALSE
- ٢٨- يمكن استخدام الأمر `surf` لرسم منحنى في ثلاثة أبعاد بلغة الماتلاب.
A) TRUE B) FALSE
- ٢٩- عند كتابة الكود `{a,b}={1,1}; {a++, ++b}` في برنامج الماتلاب تكون قيم a,b الناتجة {1,2}
A) TRUE B) FALSE
- ٣٠- لإيجاد حل المعادلة الآتية $e^x - 2x - 1 = 0$ نستخدم الأمر `roots` في لغة الماتلاب
A) TRUE B) FALSE
- ٣١- لتحليل كثيرة الحدود $x^2 - 2x + 3$ في برنامج الماتلاب نستخدم الأمر `Factor`
A) TRUE B) FALSE
- ٣٢- الأمر `hold on` يستخدم لاضافة شبكة للشكل ثنائي الأبعاد في لغة الماتلاب
A) TRUE B) FALSE

A) Poisson(6)	B) unidpdf(1:6,6)	C) normpdf(1:6,6)	D) unifpdf(6)
١٢- لإيجاد رقم عشوائي في الفترة (a,b) نستخدم الأمر.....			
A) a+(b-a)*rand(1,1)	B) (b-a)*rand(1,1)		
C) a+(b-a)*rand(a,b)	D) a+b*rand(1,1)		

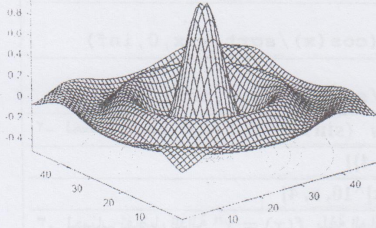
* إذا كان الكود التالي يستخدم لرسم السطح الموضح في الفراغ في ضوء ذلك أجب عن
الثلاث فقرات الآتية



```
[x,y] = ...①.. (-12:0.5:12, -12:0.5:12);
r = sqrt(x.^2 + y.^2);
z = sin(x) ./ r;
figure
.....②... (z)
.....③..... cool
```

- ١٣- نستخدم الأمر ① لتعريف قيم المتغيرين x, y :
 (A) grid off (B) grid on (C) mesh (D) meshgrid
- ١٤- لرسم هذا السطح في برنامج الماتلاب نستخدم الأمر ② :
 (A) plot3D (B) surfc (C) surf (D) plot3
- ١٥- الأمر ③ المناسب لتغيير ألوان الشكل ثلاثي الأبعاد هو
 (A) mapcolor (B) plot3DColor (C) plotColor (D) Colormap

١٦- لحساب تفاضل الدالة الرابع $y(x) = \sqrt{(x-1)(x-2)}$ بلغة الماتلاب نستخدم الكود			
A) syms x; f=sqrt((x-1)(x-2)); D=simple(diff(f,x,4))			
B) f=sqrt((x-1)*(x-2)); D=simple(diff(f,x,4))			
C) syms x; f=sqrt((x-1)*(x-2)); D=simple(diff4(f,x))			
D) syms x; f=sqrt((x-1)*(x-2)); D=simple(diff(f,x,4))			
١٧- لحساب التفاضل الرابع للدالة $(\sin x)^{10}$ بلغة الماتلاب نستخدم الكود			
A) D[Sin[x]^10, {x, 4}]		B) D[Sin(x)^10, {x, 4}]	
C) Diff[Sin[x]^10, {x, 4}]		D) syms x; D[Sin[x]^10, x, 4]	
١٨- لحساب تفاضل الدالة $f(x) = x^n$ بلغة الماتلاب نستخدم الكود			
A) Diff[x^n, x]	B) D[x^n, x]	C) syms x; D[x^n, x]	D) syms x n; D[x^n, x]

Department of Mathematics		قسم الرياضيات
Faculty of science		كلية العلوم
الاختبار النهائي لمقرر حسابات علمية ٢		
الدرجة الكلية: ٥٠ درجة	الفصل الدراسي الثاني ٢٠٢٤/٢٠٢٥ م	الفرقة : المستوى الرابع الكود : ٤٦٢ رك

السؤال الاول : اختر الاجابة الصحيحة و قم بتظليلها في البانيل شيت

١- لحساب التكامل $\int_0^{\infty} \frac{\cos x}{\sqrt{x}} dx$ بلغة الماتلاب نستخدم الكود			
A) I1=int(cos(x)/sqrt(x),x,0,inf)	B) syms x; I1=integrate(cos(x)/sqrt(x),x,0,inf)		
C) syms x; I1=int(cos(x)/sqrt(x),x,0,inf)	D) syms x; I1=int(cos(x)/sqrt(x),x,0,inf)		
٢- لحساب التفاضل الرابع للدالة $(\sin x)^{10}$ بلغة الماتلاب نستخدم الكود			
A) D[Sin(x)^10, {x, 4}]	B) D[Sin(x)^10, {x, 4}]		
C) Diff[Sin(x)^10, {x, 4}]	D) syms x; D[Sin(x)^10, x, 4]		
٣- لحساب تفاضل الدالة $f(x) = x^n$ بلغة الماتلاب نستخدم الكود			
A) Diff[x^n, x]	B) D[x^n, x]	C) syms x; D[x^n, x]	D) syms x; D[x^n, x]
٤- لاجاد حل المعادلة الآتية $e^x - 2x - 1 = 0$ نستخدم الأمر			
A) solve	B) sol	C) roots	D) polyval
٥- لحساب التكامل $\int \frac{1}{x^3+1} dx$ بلغة الماتلاب نستخدم الكود			
A) Integrate(1/(x^3+1), x)	B) Int[1/(x^3+1), x]		
C) integrate(1/(x^3+1), x)	D) syms x; Int[1/(x^3+1), x]		
٦- لحساب تفاضل الدالة $y(x) = \sqrt{x \sin x \sqrt{1 - e^x}}$ بلغة الماتلاب نستخدم الكود			
A) syms x; D1=simple(diff(f)); f=sqrt(x*sin(x)*sqrt(1-exp(x)));	B) f=sqrt(x*sin(x)*sqrt(1-exp(x))); D1=simple(diff(f))		
C) syms x; f=sqrt(x*sin(x)*sqrt(1-exp(x))); D1=simple(diff(f))	D) syms x; f=sqrt(x*sin(x)*sqrt(1-exp(x))); D1=simple(diff(f))		
٧- لتحليل كثيرة الحدود $x^2 - 2x + 3$ في برنامج الماتلاب نستخدم الأمر			
A) Expand	B) Factor	C) Apart	D) Simplify
٨- لحساب التباين للمتجه $x=[4 8 20 2 7 10]$ نستخدم الأمر			
A) var(x)	B) std(x)	C) mean(x)	D) median(x)
٩- لحساب دالة التوزيع التراكمي F(x) في الماتلاب نستخدم			
A) pdf	B) cdf	C) makedist	D) distmake
١٠- الدالة تعطي القيمة y لكثيرة الحدود التي معاملاتها a عند الاحداثي x			
A) random(a,x)	B) polyfit(a,x)	C) polyval(a,x)	D) polyval(a,y)
١١- لحساب دالة التوزيع المناسبة لتجربة القاء حجر نرد نستخدم الأمر			

Department of Mathematics		قسم الرياضيات
Faculty of science		كلية العلوم
الاختبار النهائي لمقرر حسابات علمية ٢		
الفرقة : المستوى الرابع الكود : ٤٦٢ رك	الفصل الدراسي الثاني ٢٠٢٤/٢٠٢٥ م	زمن الاختبار : ساعتان الدرجة الكلية : ٥٠ درجة

السؤال الاول : اختر الاجابة الصحيحة و قم بتظليلها في البابل شيت

١- لحساب التكامل $\int_0^{\infty} \frac{\cos x}{\sqrt{x}} dx$ بلغة الماتلاب نستخدم الكود			
A) I1=int(cos(x)/sqrt(x),x,0,inf)	B) syms x; I1=integrate(cos(x)/sqrt(x),x,0,inf)		
C) syms x; I1=int(cos(x)/sqrt(x),x,0,inf)	D) syms x; I1=int(cos(x)/sqrt(x),x,0,inf)		
٢- لحساب تفاضل الدالة $(\sin x)^{10}$ بلغة الماتلاب نستخدم الكود			
A) D[Sin(x)^10, {x, 4}]	B) D[Sin(x)^10, {x, 4}]		
C) Diff[Sin(x)^10, {x, 4}]	D) syms x; D[Sin(x)^10, x, 4]		
٣- لحساب تفاضل الدالة $f(x) = x^n$ بلغة الماتلاب نستخدم الكود			
A) Diff[x^n, x]	B) D[x^n, x]	C) syms x; D[x^n, x]	D) syms x n; D[x^n, x]
٤- لايجاد حل المعادلة الآتية $e^x - 2x - 1 = 0$ نستخدم الأمر			
A) solve	B) sol	C) roots	D) polyval
٥- لحساب التكامل $\int \frac{1}{x^3+1} dx$ بلغة الماتلاب نستخدم الكود			
A) Integrate(1/(x^3+1), x)	B) Int[1/(x^3+1), x]		
C) integrate(1/(x^3+1), x)	D) syms x; Int[1/(x^3+1), x]		
٦- لحساب تفاضل الدالة $y(x) = \sqrt{x \sin x \sqrt{1 - e^x}}$ بلغة الماتلاب نستخدم الكود			
A) syms x; D1=simple(diff f); f=sqrt(x*sin(x)*sqrt(1-exp(x)));	B) f=sqrt(xsin(x)*sqrt(1-exp(x))); D1=simple(diff(f))		
C) syms x; f=sqrt(x sin(x) sqrt(1-exp(x))); D1=simple(diff(f))	D) syms x; f=sqrt(x*sin(x)*sqrt(1-exp(x))); D1=simple(diff(f))		
٧- لتحليل كثيرة الحدود $x^2 - 2x + 3$ في برنامج الماتلاب نستخدم الأمر			
A)Expand	B)Factor	C)Apart	D)Simplify
٨- لحساب التباين للمتجه $x=[4 8 20 2 7 10]$ نستخدم الأمر			
A) var(x)	B) std(x)	C)mean(x)	D)median(x)
٩- لحساب دالة التوزيع التراكمية F(x) في الماتلاب نستخدم			
A) pdf	B) cdf	C) makedist	D) distmake
١٠- الدالة تعطي القيمة y لكثيرة الحدود التي معاملاتها a عند الاحداثي x			
A)random(a,x)	B) polyfit(a,x)	C) polyval(a,x)	D) polyval(a,y)
١١- لحساب دالة التوزيع المناسبة لتجربة القاء حجر نرد نستخدم الأمر			

26. ANSI stands for _____
- American National Standards Institute
 - American National Standard Interface
 - American Network Standard Interfacing
 - American Network Security Interrupt
27. _____ register Connected to the Processor bus is a single-way transfer capable.
- PC
 - IR
 - Temp
 - Z
28. In multiple Bus organisation, the registers are collectively placed and referred as _____
- Set registers
 - Register file
 - Register Block
 - Map registers
29. The main advantage of multiple bus organisation over a single bus is _____
- Reduction in the number of cycles for execution
 - Increase in size of the registers
 - Better Connectivity
 - None of the mentioned
30. The ISA standard Buses are used to connect _____
- RAM and processor
 - GPU and processor
 - Harddisk and Processor
 - CD/DVD drives and Processor
31. The duration between the read and the mfc signal is _____
- Access time
 - Latency
 - Delay
 - Cycle time
32. The minimum time delay between two successive memory read operations is _____
- Cycle time
 - Latency
 - Delay
 - None of the mentioned
33. _____ is the bottleneck, when it comes computer performance.
- Memory access time
 - Memory cycle time
 - Delay
 - Latency
34. VLSI stands for _____
- Very Large Scale Integration
 - Very Large Stand-alone Integration
 - Volatile Layer System Interface
 - None of the mentioned
35. A memory organisation that can hold upto 1024 bits and has a minimum of 10 address lines can be organized into _____
- 128 X 8
 - 256 X 4
 - 512 X 2
 - 1024 X 1
36. The RAMBUS requires specially designed memory chips similar to _____
- SRAM
 - SDRAM
 - DRAM
 - DDRRAM
37. The reason for the implementation of the cache memory is _____

